



SPRAYERS
& EQUIPMENT

TRS 2-ROW NARROW V-SERIES SPRAYER



TRS 2-ROW NARROW V-SERIES SPRAYER

MODEL NAME: VN2-1500

The TRS V-Series Narrow Sprayer incorporates the TRS vineyard sprayer fan technology and delivers a commercial, high performance, power efficient sprayer system on a smaller scale. This makes the TRS V Spray technology available to smaller vineyards that want 2-Row efficiency, without compromising performance. The reduced size and weight allows the option to use smaller tractors.

The sprayer is suitable for vineyard with row widths down to 1.8m*. The TRS Narrow Sprayer has been designed without compromising quality, performance and safety. Our key focus has been to deliver the features and benefits of our highly regarded industry standard commercial TRS Sprayer range.

FEATURES:

- 1500L Poly main spray tank
- 17L Freshwater hand wash tank
- 120L Freshwater sprayer flush tank
- Hot dip galvanised chassis and boom
- Genuine Weber QU13.5 Tangential fans (Maximum treatable canopy height 2m)
- Auto rate controller
- PTO Spray pump option
- Hydraulic spray delivery pump, hydraulic boom fold and fan drive
- Bertolini 2150 spray pump, delivering a maximum volume of 105lpm at 10bar max. operating pressure
- Drawbar with single pivot eyelet
- Operating row width range 1.8m* - 2.5m (1.8m - 1.9m requires special options)
- Single ADR axle equipment with 13.0/55-16 14 ply high quality tyres
- Bravo 180s controller, multi-row version

BENEFITS:

- Spray delivery pump and fans are hydraulically driven, eliminating the need for a pto system. This allows greater turning angles and removes drive shaft safety and maintenance and reduces pump maintenance.
- Tangential fans allow a targeted delivery result, requires less power and has better management of spray drift
- Boom system offers simplified folding for transport mode and removes weight transfer when folding
- Tank design includes a 7-degree tapered tank floor with a centralised sump for ease of removal of tank content and reducing tank surge when on steeper vineyards

ADDITIONAL OPTIONS:

- Upgrade to GPS speed sensor for rate control distance and travel speed
- Upgrade to ISOBUS spray controller - Hydraulic function cable, speed input from wheel speed sensor
- Upgrade to IBX100 spray controller - Tank level sensor, Digital pressure sensor, GPS speed sensor or Delta 70VT with tractor ISOBUS installation kit
- Upgrade to 3-point linkage hitch drawbar - Recommended for sub 2.0mtr row widths
- *Option to change to 10.0/75-15.3 wheels for reduced track width - Recommended for sub 2.0mtr row widths

MODEL DIMENSIONS:

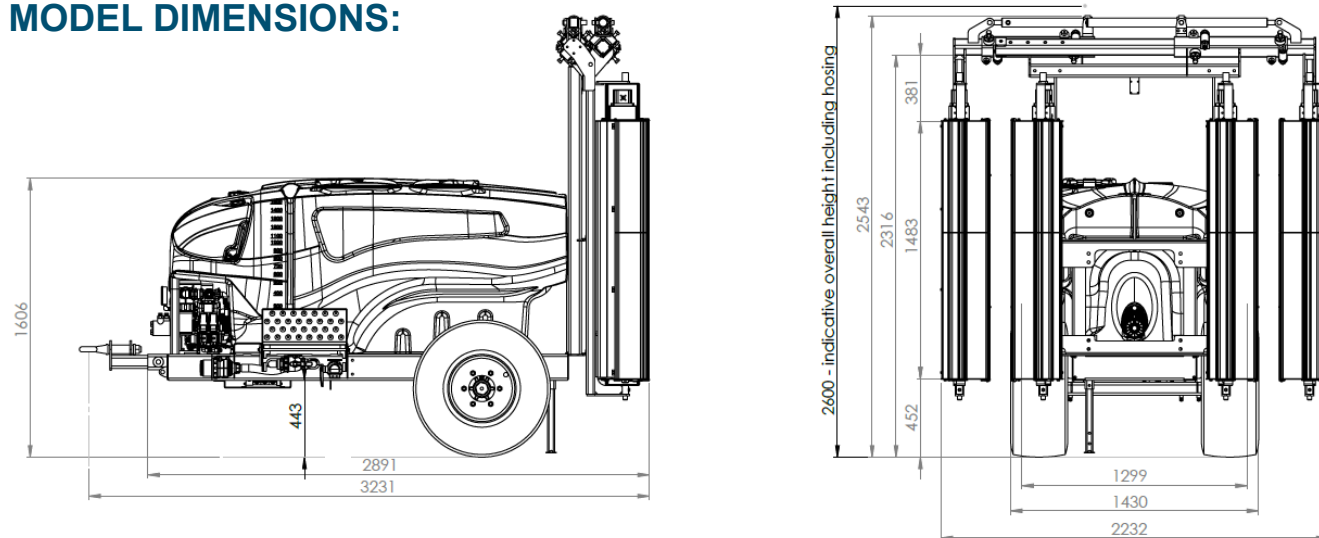

Distributed by:

TRS Wholesale Limited

9B / 40 Waters Ave, Blenheim 7201, New Zealand

Postal Address : PO Box 162, Blenheim 7240, New Zealand

Telephone : +64 3 572 5150

Email: sales@trswholesale.co.nz | trsequipment.co.nz

Your local dealer: